

SW75N03

Preliminary

Power MOSFET

N-CHANNEL ENHANCEMENT MODE FIELD EFFECT TRANSISTOR

DESCRIPTION

The **SW75N03** uses advanced trench technology to provide excellent $R_{DS(ON)}$, low gate charge and operation with low gate voltages. This device is suitable for use as a load switch or in PWM applications.

FEATURES

* $R_{DS(ON)} < 7m\Omega @ V_{GS}=10V$

* $R_{DS(ON)} < 10m\Omega @ V_{GS}=4.5V$

SYMBOL

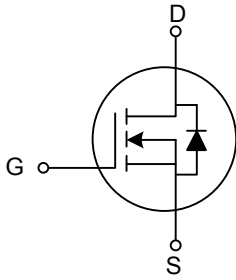

ORDERING INFORMATION

Ordering Number			Package	Pin Assignment			Packing
Normal	Lead plating Free	Halogen Free		1	2	3	
SW75N03-TA3-T	SW75N03L-TA3-T	SW75N03G-TA3-T	TO-220	G	D	S	Tube

SW75N03L-TA3-T (1) Packing Type (2) Package Type (3) Lead Plating	(1) T: Tube (2) TA3: TO-220 (3) G: Halogen Free, L: Lead Free, Blank: Pb/Sn
--	---

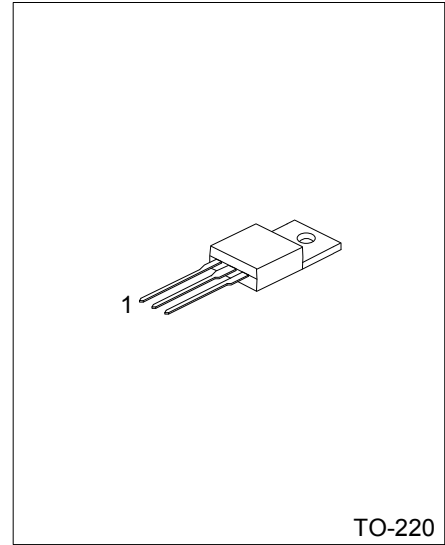

Lead-free: SW75N03L

Halogen-free: SW75N03G

■ ABSOLUTE MAXIMUM RATINGS ($T_C=25^{\circ}\text{C}$, unless otherwise specified)

PARAMETER	SYMBOL	RATINGS	UNIT
Drain-Source Voltage	V_{DSS}	30	V
Gate-Source Voltage	V_{GSS}	± 20	V
Continuous Drain Current	I_D	75	A
Pulsed Drain Current (Note 2)	I_{DM}	225	A
Single Pulsed Avalanche Current (Note 3)	I_{AS}	100	A
Single Pulsed Avalanche Energy (Note 3)	E_{AS}	228	mJ
Power Dissipation@ $T_C = 25^{\circ}\text{C}$	P_D	75	W
Derate above 25°C		0.5	W/ $^{\circ}\text{C}$
Junction Temperature	T_J	+150	$^{\circ}\text{C}$
Storage Temperature	T_{STG}	-55 ~ +175	$^{\circ}\text{C}$

Note: 1. Absolute maximum ratings are those values beyond which the device could be permanently damaged.

Absolute maximum ratings are stress ratings only and functional device operation is not implied.

2. Pulse width limited by $T_{J(MAX)}$

3. $L=20\mu\text{H}$, $I_{AS}=100\text{A}$, $V_{DD}=24\text{V}$, $R_G=25\Omega$, Starting $T_J=25^{\circ}\text{C}$

■ THERMAL DATA

PARAMETER	SYMBOL	RATINGS	UNIT
Junction to Ambient	θ_{JA}	62.5	$^{\circ}\text{C}/\text{W}$
Junction to Case	θ_{JC}	2.0	$^{\circ}\text{C}/\text{W}$

■ ELECTRICAL CHARACTERISTICS ($T_C=25^{\circ}\text{C}$, unless otherwise specified)

PARAMETER	SYMBOL	TEST CONDITIONS	MIN	TYP	MAX	UNIT
OFF CHARACTERISTICS						
Drain-Source Breakdown Voltage	BV_{DSS}	$V_{GS}=0\text{V}$, $I_D=250\mu\text{A}$	30			V
Drain-Source Leakage Current	I_{DSS}	$V_{DS}=30\text{V}$, $V_{GS}=0\text{V}$			1	μA
Gate-Source Leakage Current	Forward	I_{GSS}			100	nA
	Reverse				-100	nA
ON CHARACTERISTICS (Note)						
Gate Threshold Voltage	$V_{GS(TH)}$	$V_{DS}=V_{GS}$, $I_D=250\mu\text{A}$	1		3	V
Static Drain-Source On-Resistance	$R_{DS(ON)}$	$V_{GS}=10\text{V}$, $I_D=40\text{A}$		5	7	m Ω
		$V_{GS}=4.5\text{V}$, $I_D=37\text{A}$		7	10	m Ω
DYNAMIC PARAMETERS						
Input Capacitance	C_{ISS}	$V_{DS}=15\text{V}$, $V_{GS}=0\text{V}$, $f=1.0\text{MHz}$		3298		pF
Output Capacitance	C_{OSS}			1400		pF
Reverse Transfer Capacitance	C_{RSS}			287		pF
SWITCHING PARAMETERS						
Turn-ON Delay Time	$t_{D(ON)}$	$V_{DD}=15\text{V}$, $I_D=60\text{A}$, $V_{GS}=10\text{V}$, $R_{GEN}=6\Omega$		20	38	ns
Turn-ON Rise Time	t_R			12	23	ns
Turn-OFF Delay Time	$t_{D(OFF)}$			113	198	ns
Turn-OFF Fall-Time	t_F			40	78	ns
Total Gate Charge	Q_G			48	55	nC
Gate-Source Charge	Q_{GS}	$V_{DS}=15\text{V}$, $V_{GS}=5\text{V}$, $I_D=40\text{A}$		10		nC
Gate-Drain Charge	Q_{GD}			27		nC
DRAIN-SOURCE DIODE CHARACTERISTICS AND MAXIMUM RATINGS						
Diode Forward Voltage(Note)	V_{SD}	$V_{GS}=0\text{V}$, $I_S=40\text{A}$			1.3	V
Maximum Body-Diode Continuous Current	I_S				75	A

Note: Pulse Test: Pulse Width $\leq 300\mu\text{s}$, Duty Cycle $\leq 2\%$.

