

Fig 7. Breakdown Voltage Variation vs. Junction Temperature

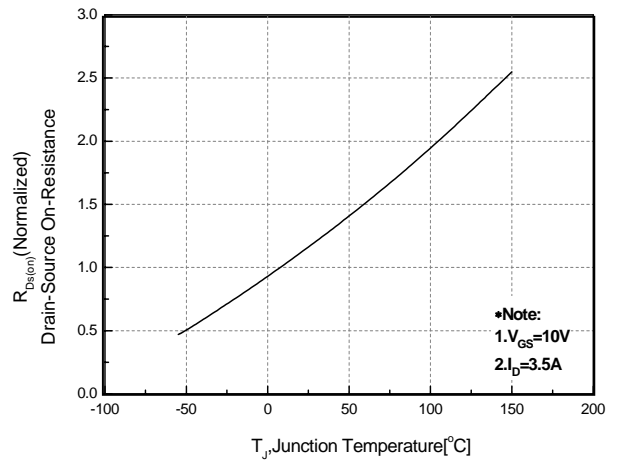

Fig 8. On-Resistance Variation vs. Junction Temperature

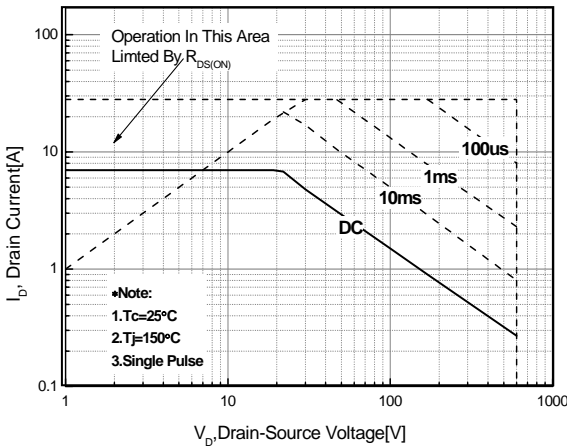

Fig 9. Maximum Safe Operating

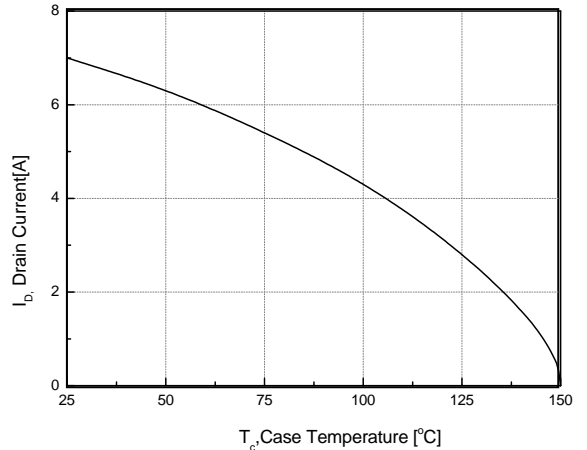

Fig 10. Maximum Drain Current Vs. Case Temperature

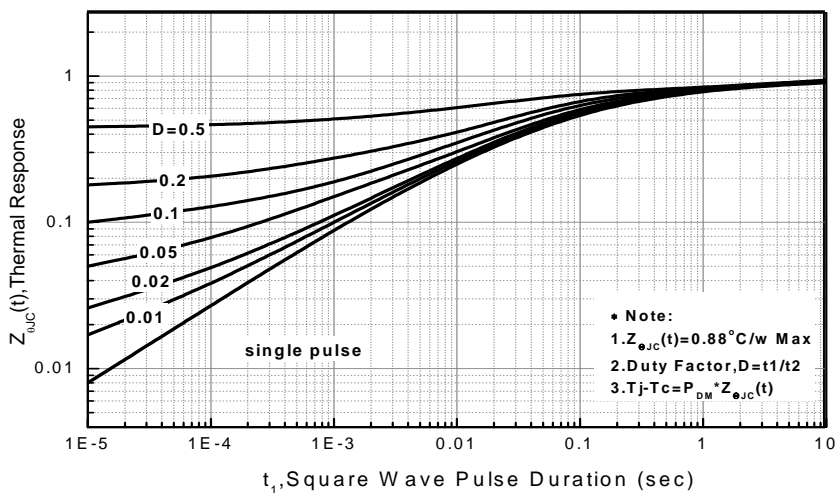

Fig 11. Transient Thermal Response Curve

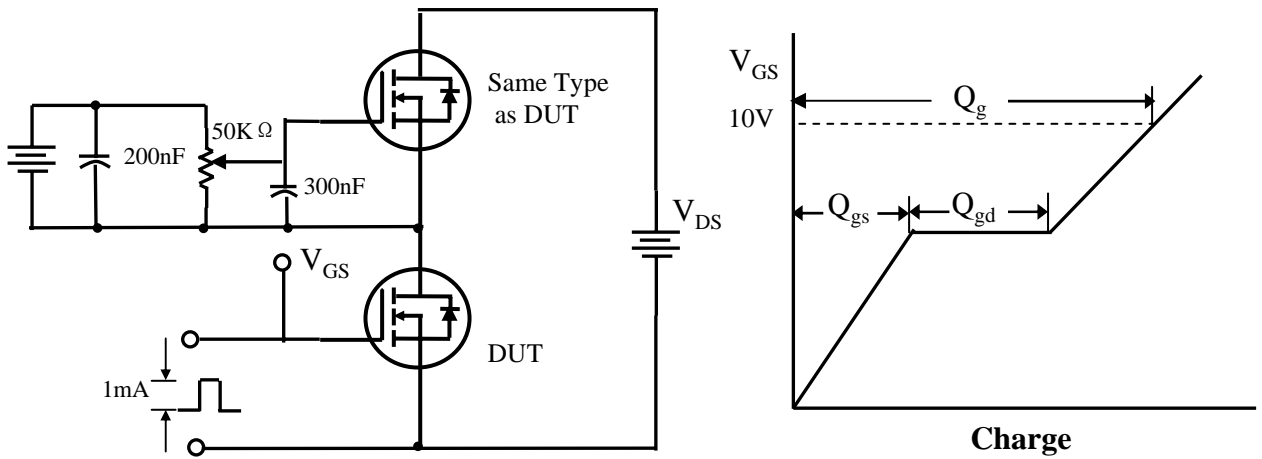

Fig 12. Gate Charge test Circuit & Waveforms

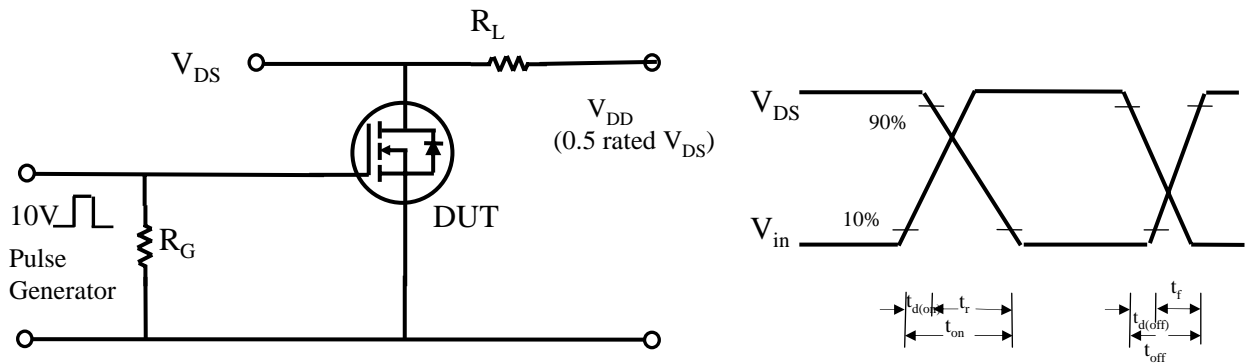

Fig 13. Switching test Circuit & Waveforms

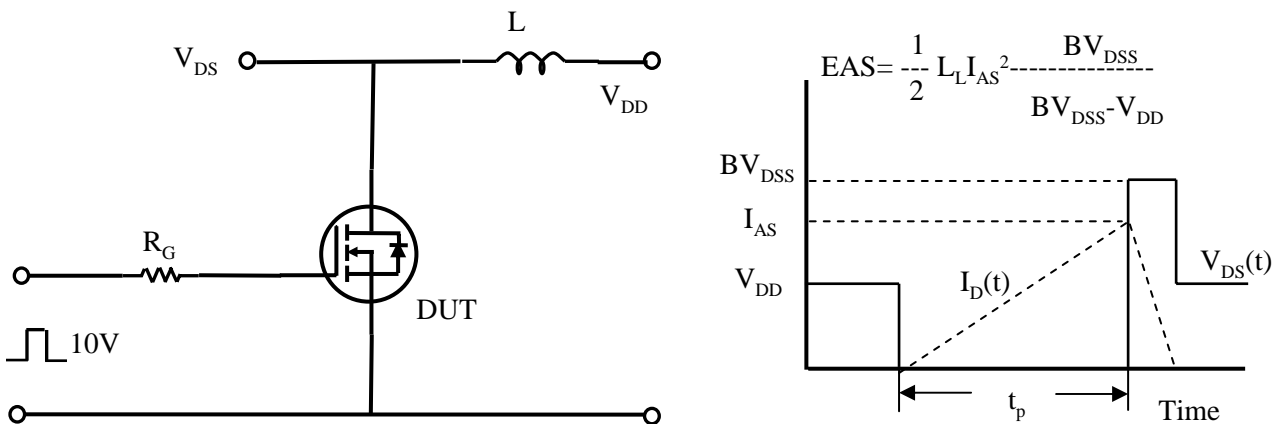

Fig 14. Unclamped Inductive Switching test Circuit & Waveforms

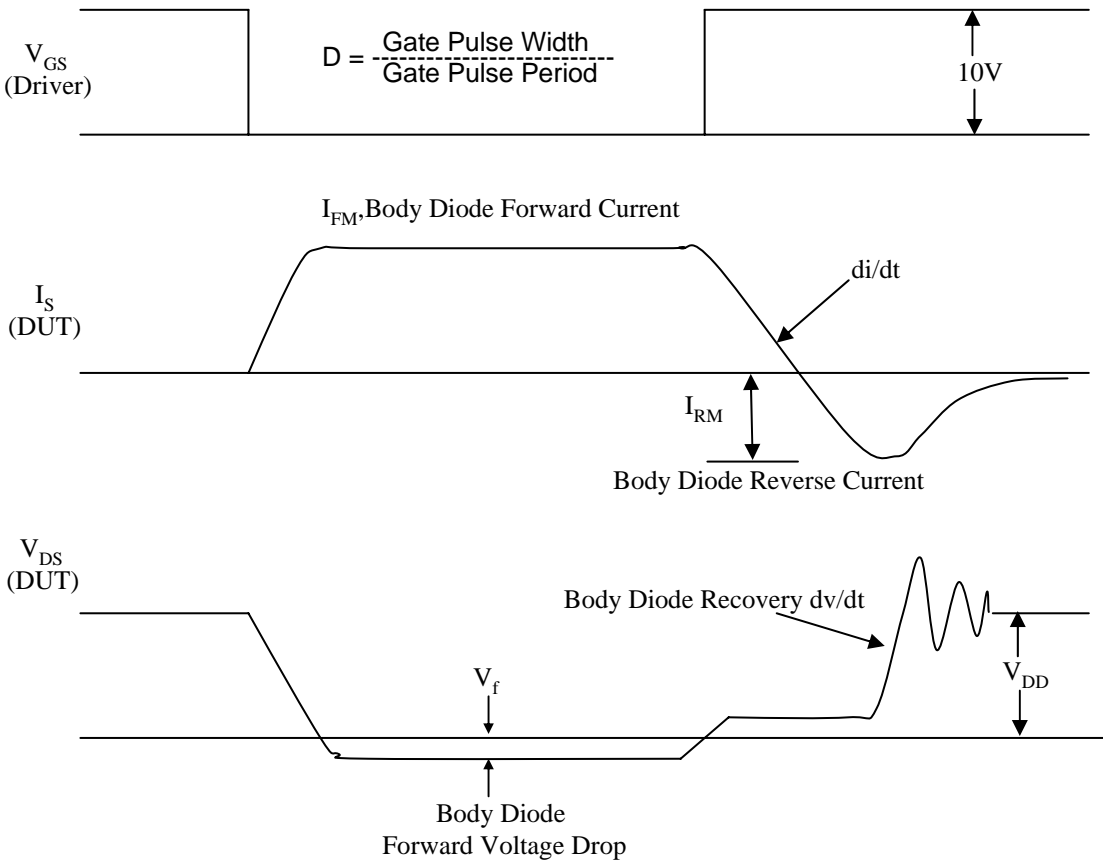
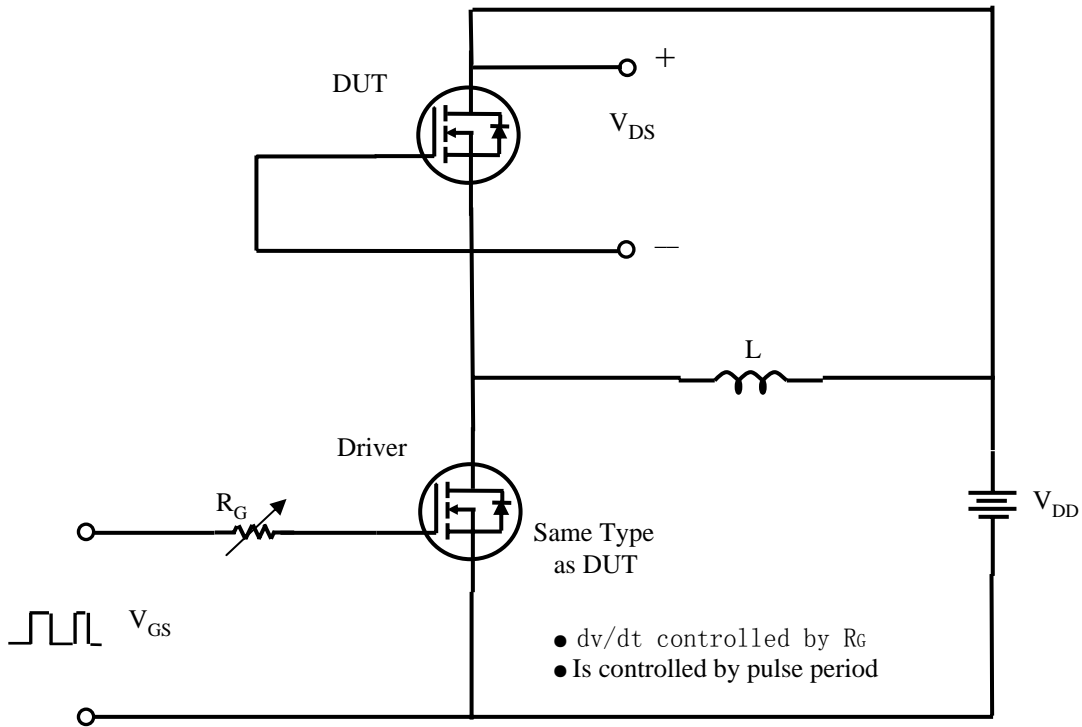

Fig 15. Peak Diode Recovery dv/dt test Circuit & Waveforms